

ORDINANCE NO. _____

**AN ORDINANCE OF THE CITY OF WEST HOLLYWOOD,
APPROVING ZONE TEXT AMENDMENT 14-0006 FOR
THE WEST HOLLYWOOD WEST NEIGHBORHOOD
OVERLAY DISTRICT.**

The City Council of the City of West Hollywood does hereby ordain as follows:

SECTION 1. The City of West Hollywood initiated a Neighborhood Overlay District for the West Hollywood West neighborhood to address concerns about new single-family houses and additions.

SECTION 2. A public hearing was duly noticed and held at the Planning Commission meeting of Thursday, October 02, 2014 and continued to October 16, 2014. The Planning Commission reviewed the staff report, considered all pertinent testimony, and in a 4 to 1 vote recommended approval of Zone Text Amendment 2014-006 to the City Council with Resolution No. PC 14-1102.

SECTION 3. The City Council of the City of West Hollywood properly reviewed and considered this matter at a public hearing on November 3, 2014. A public hearing was duly noticed for the City Council meeting by publication in the Beverly Press newspaper on October 23, 2014, the West Hollywood Independent Newspaper on October 23, 2014, required state and local agencies, the City website and by announcement on City Channel 6 by October 23, 2014. Mailed notices to all property owners and residents in the R1B Zone of the West Hollywood West neighborhood were postmarked on October 23, 2014.

SECTION 4. This project is Categorically Exempt from the California Environmental Quality Act (CEQA) pursuant to Section 15061. This section of CEQA states that CEQA applies only to projects which have the potential for causing a significant effect on the environment. Where it can be seen with certainty that there is no possibility that the activity in question may have a significant effect on the environment, the activity is not subject to CEQA. The proposed text changes to the Zoning Ordinance impose certain requirements in the R1B Zone in the West Hollywood West Neighborhood. This project qualifies for this exemption because the text changes only affect properties zoned for single family houses and duplexes. The proposed changes do not modify the total number of units permitted on a parcel, number of on-site parking spaces, nor the size, scale, height, or density of the structures permitted in the WHMC.

The construction or conversion of single family houses and duplexes are categorically exempt under section 15303 of California Environmental Quality Act (CEQA). Because the legislature has determined that the underlying projects (single family homes and duplexes) pertaining to the text changes do not have the potential to create significant environmental impacts and there are no changes to parking, size, size scale, height or density requirements, the proposed text changes to the City's Zoning Ordinance are exempt from further CEQA review under 14 Cal. Code Regs. §§ 15303.

SECTION 5. The West Hollywood City Council hereby finds that Zone Text Amendment 2014-001 is consistent with the Goals and Policies of the General Plan, specifically Policy Goal LU-10 which states that the City should “Encourage single-family residential neighborhoods that are well maintained and landscaped and include a diverse range of house sizes and architectural styles.” The proposed development of Design Guidelines and Neighborhood Overlay District are consistent with the goals for the R1B areas to further ensure new homes are individually designed and are reviewed with consideration to scale and form.

SECTION 6. A new Section 19.14.110 West Hollywood West Neighborhood Overlay District (-WHWNOD) is added to Chapter 19.14 of Title 19 of the West Hollywood Municipal Code to read as follows:

19.14.110 West Hollywood West Neighborhood Overlay District (-WHWNOD)

A. *Purpose.* The West Hollywood West neighborhood is composed of an eclectic mix of homes creating a distinct neighborhood character. The West Hollywood West Neighborhood Overlay District (WHWNOD) is used to provide additional development standards designed to maintain the character of the neighborhood.

The WHWNOD has been developed to achieve the following goals:

1. Manage change within the West Hollywood West Neighborhood;
2. Protect desirable qualities and characteristics of the neighborhood valued by current residents and property owners;
3. Ensure that new residential construction and remodels enhance the existing eclectic character and quality of the West Hollywood West neighborhood;
4. Allow flexibility for creative design solutions; and
5. Provide clear rules and guidelines for owners, builders, and design professionals to facilitate an efficient process when preparing applications for new single-family/multi-family dwellings and additions.

This Section is intended to amend and supplement the development standards set forth in Title 19 Zoning Ordinance of the West Hollywood Municipal Code. Residential development within the WHWNOD shall comply with the Title 19 Zoning Ordinance to the extent not in conflict with this Section. This Section shall control in the event of any conflicts with another provision of the Title 19 Zoning Ordinance. The West Hollywood West Neighborhood Design Guidelines are intended to supplement the WHWNOD regulations in this Section to help achieve the goals set forth above.

B. *Applicability.* The West Hollywood West Neighborhood Overlay District shall be combined with all R1-B zoned properties within the following boundaries: Melrose Avenue to the north, North Doheny Drive to the west, North La Cienega Boulevard to the east, and Beverly Boulevard to the south.

C. *Allowed Land Uses.* Any land use allowed in the primary R1-B zoning district may be allowed within the WHWNOD.

D. *Permit Requirements.* The land use permit requirements of the primary R1-B zoning district shall apply to all proposed developments and land uses within the WHWNOD.

E. *Development and Land Use Standards.* Proposed development and land uses within the WHWNOD shall be subject to all applicable development standards of the primary R1-B zoning district, and of Article 19-3 (Site Planning and General Development Standards), in addition to the standards set forth in this Section.

TABLE 2-7
WEST HOLLYWOOD WEST NEIGHBORHOOD DISTRICT
GENERAL DEVELOPMENT STANDARDS

[Explanatory Notes Follow the Table, on Next Page]

Development Feature	Requirement	
	R1B	WHWNOD
Minimum lot area ¹	5,000 sq. ft.	
Residential density ^{2, 6, 7}	2 units per lot of less than 8,499 sq ft; See Table 2-4 in Section 19.06.040.	
Floor area ratio (FAR)	0.5	0.5 ¹²
Setbacks required Primary structures	<i>Minimum setbacks required. See Section 19.20.150 for setback measurement.</i>	
Front, 1st story	Average of front setbacks of the 2 structures closest to the front property lines on the 2 adjacent parcels, with the following minimums/maximums. ³	
	10 ft. min. in Norma Triangle, 15 ft. min. elsewhere; 30 ft. max.	15 ft. minimum, 30 ft. maximum.
Front, 2nd & upper stories	An additional 6 ft. for 2nd and upper stories in addition to the 1st story setback. ⁴	As required by Section 19.14.110.E.1.
Sides, interior lot	5 ft. For lots less than 50 ft. wide, 10% of average lot width, with 3 ft. min. (See 19.36.320 for additions to nonconforming buildings.)	5 ft. For lots less than 50 ft. wide, 10% of average lot width, with 3 ft. min. (See 19.36.320 for additions to nonconforming buildings.)
Street side, corner lot	5 ft.	5 ft.
	10 ft. for reversed corner lots. ⁵	
Rear	15 ft. For lots with a depth less than 75 ft., 20% of the average lot depth, but not less than 10 ft.	
Between structures	As required by Section 19.20.040 (Distance Between Structures)	

Flag lots	As required by Section 19.20.150 (Setback Measurement and Projections into Yards)	
Open space	None required other than setbacks	
Basement, front setback	none	10 ft
Basement, side setback	none	5 ft.
Basement, rear setback	none	5 ft.
Height limit Primary structures	Maximum structure height. See Section 19.20.080 (Height Measurement and Exceptions).	
	25 ft., 2 stories	
Height limit Accessory	15 ft., 1 story	12 ft., 1 story, where within 5 ft. of the property line; 15 ft., 1 story, where 5 ft. or beyond from the property line. ⁹
Landscaping	As required by Chapter 19.26 (Landscaping Standards) ¹⁰	
Safety and Seismic Safety	For new construction and building additions, as required by Chapter 19.32 (Seismic Safety). Critical facilities, sensitive facilities (such as schools and daycare) and high occupancy facilities (such as religious facilities and hotels) are also subject to Chapter 19.32.	
Parking	As required by Chapter 19.28 (Off-Street Parking and Loading Standards) ¹¹	
Sidewalks	Sidewalks shall be provided at a minimum width of 10 ft. See Section 19.20.160.	
Signs	As required by Chapter 19.34 (Sign Standards)	

Notes:

- (1) Minimum lot area for parcels proposed in new subdivisions and lot line adjustments. Condominium, townhome, or planned development projects may be subdivided with smaller parcel sizes for ownership purposes, with the minimum lot area requirement determined through the subdivision review process, provided that the overall development site complies with the lot area requirements of this chapter.
- (2) Maximum number of dwellings allowed for each specified unit of land. See also Chapter 19.22 (Affordable Housing Requirements and Incentives) for possible density bonuses.
- (3) If a parcel on either side of the site is not zoned residential, or if the site is a corner lot, the first two adjacent residential lots shall be used for the purposes of calculating the average setback.
- (4) The Director may modify or waive this requirement to accommodate what he/she deems to be exemplary design.
- (5) Where the front yard of a key lot adjoining a reversed corner lot is less than 10 feet in depth, the reversed corner lot may have a street side yard of the same depth, to a minimum of five feet. See Figure 2-1.
- (6) Density limits may be exceeded to permit legalization of illegal dwelling units in accordance with Section 19.36.270.
- (7) See also Section 19.06.080 for required density development standards.

- (8) See 19.14.110.E.1 for relevant building massing and modulation standards for the West Hollywood West neighborhood.
- (9) See Section 19.14.110.E.4 for additional rear accessory structure standards in the West Hollywood West Overlay District.
- (10) See Section 19.14.110.E.5 for additional landscape standards in the West Hollywood West Overlay District.
- (11) See Section 19.14.110.E.3 for additional parking standards in the West Hollywood West Overlay District.
- (12) Garages attached to the primary structure shall be included in the FAR. Detached garages up to 400 square feet shall not be included in the FAR. Accessory structures, other than garages, are included in the FAR calculation.

Building Massing and Modulation.

a. All primary two-story structures and primary structures greater than fifteen (15) feet in height shall meet ONE of the following conditions:

- (1) Floor area of the second level shall not exceed 75% of the floor area of the primary structure's first level, and front and side building elevations shall not be single solid planes, with a variation of at least three (3) feet in depth and width; OR

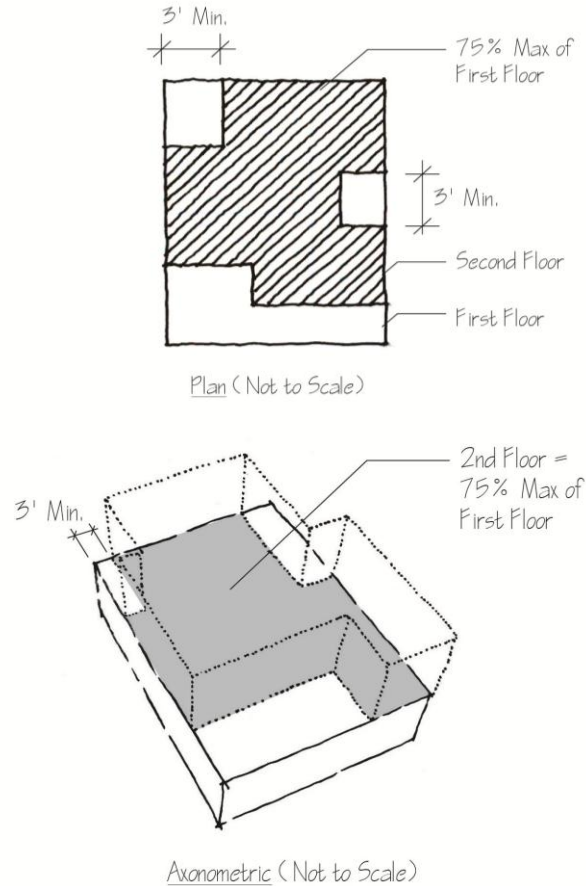
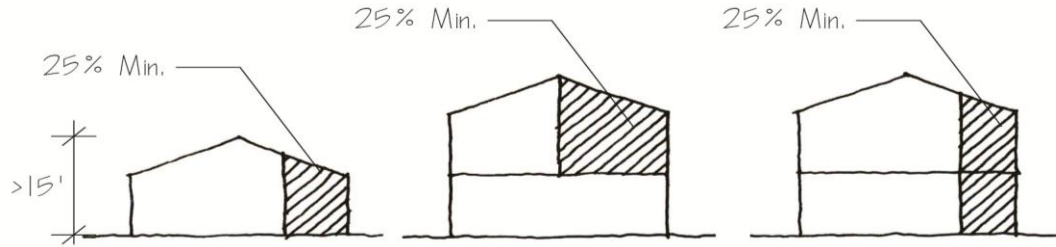
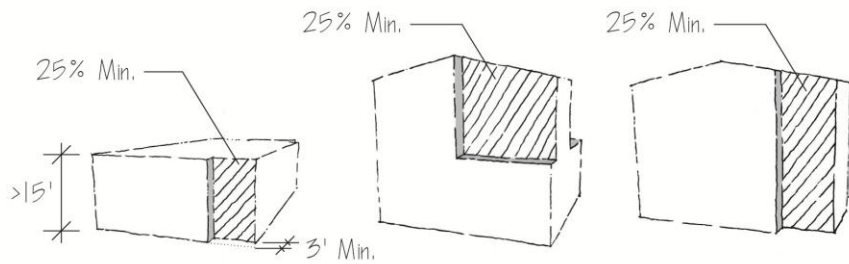

Figure WHWNOD-1
SECOND FLOOR AREA AS A PERCENT OF FIRST FLOOR

- (2) A minimum of 25% of each building elevation shall be set back at least three (3) feet from the remaining area of the elevational plane.



Elevations (Not to Scale)



Axonometric (Not to Scale)

**Figure WHWNOD-2
VARIATION OF ELEVATIONAL PLANE**

- a. No primary structure shall have a single, unbroken roofline across the front of the building. At least three (3) feet of the roofline frontage shall have either a vertical change of direction or a three (3) foot minimum horizontal change of direction. The Director may waive this requirement if the width of the primary structure's frontage is less than fifty percent (50%) of the lot width, or if the roof line is curved.

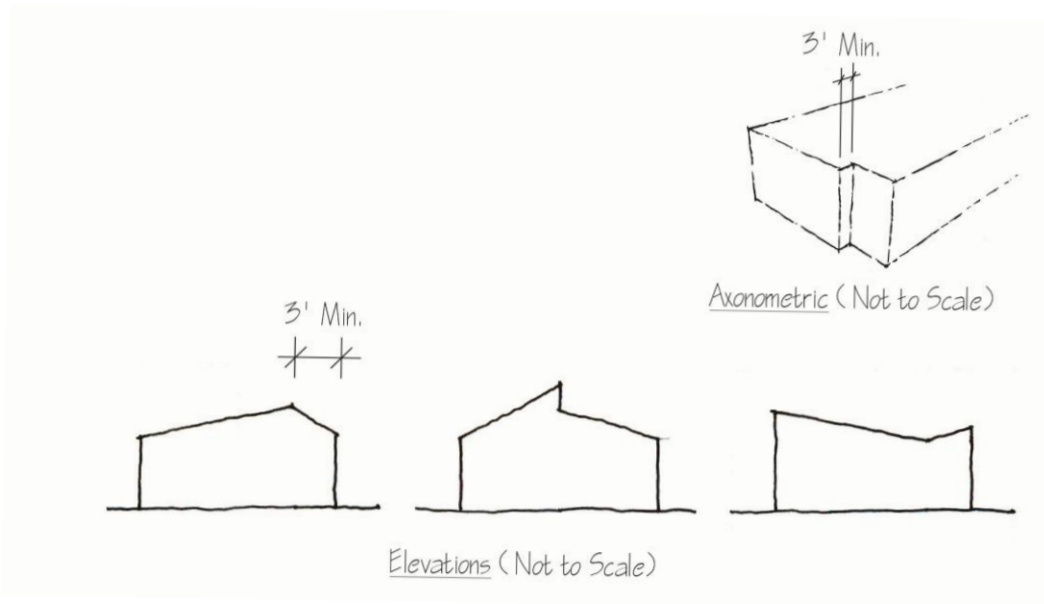
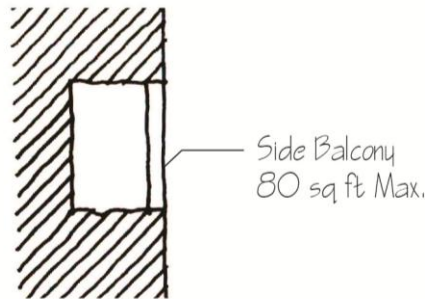

Figure WHWNOD-3
ROOFLINES WITH CHANGE OF DIRECTION

b. Balconies

- (1) *Front Balcony*. Size limitations and privacy screen requirements do not apply to a balcony that is located on a building's front elevation.
- (2) *Side Balcony Size*. A balcony that is located on a building's interior side elevation shall not be larger than eighty (80) square feet in area.
- (3) *Rear Balcony Size*. A balcony that is located on a building's rear elevation shall not be larger than one hundred forty-four (144) square feet in area.
- (4) *Privacy Screen Location*. If a privacy screen is provided, it shall be set back at least eighteen (18) inches from the exterior building face. If a privacy screen is flush with the exterior building face, it will be included as floor or wall area for the purpose of provision 19.14.110.E.1.a. Ensure that privacy screen does not prevent proper drainage from the balcony.
- (5) *Allowed Projections into Setbacks*. All projections into setbacks shall meet the standards set forth in Section 19.20.150.E of the Municipal Code, provided that balconies shall not project into the required side setback.



Plan (Not to Scale)

Figure WHWNOD-4
SIDE BALCONY SIZE

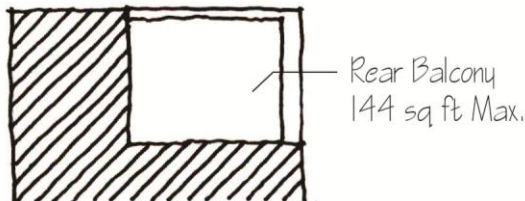

Plan (Not to Scale)

Figure WHWNOD-5
REAR BALCONY SIZE

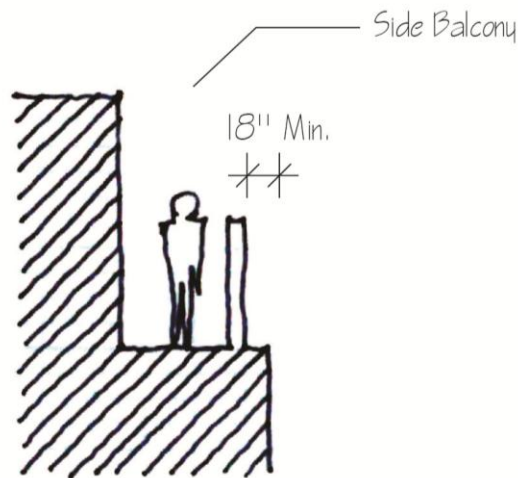

Section (Not to Scale)

**Figure WHWNOD-6
BALCONY PRIVACY SCREEN LOCATION**

- c. No roof decks shall be permitted on any structure.
 - d. Basements shall be permitted and shall not be included in the calculation of FAR.
1. Height Measurement Exceptions. All structures shall comply with the height limits in Section 19.20.080 of the Municipal Code. Notwithstanding 19.20.080.C.2 architectural projections that provide passive solar and venting functions that are not more than fifteen percent (15%) of the roof area shall not be considered mechanical equipment as described in Subsection C-419.20.080.C.4.

2. Parking and Driveways. W.H.M.C Chapters 19.28 and 19.36 apply in the WHWNOD, except as otherwise provided below:

- a. The maneuvering room required under 19.28.090.A.1 shall not be required for single-family dwellings and duplexes.
- b. Required parking may be located between the front setback and the front of a residential unit, provided that the parking area is not wider than 10 feet, and is not within the front setback.

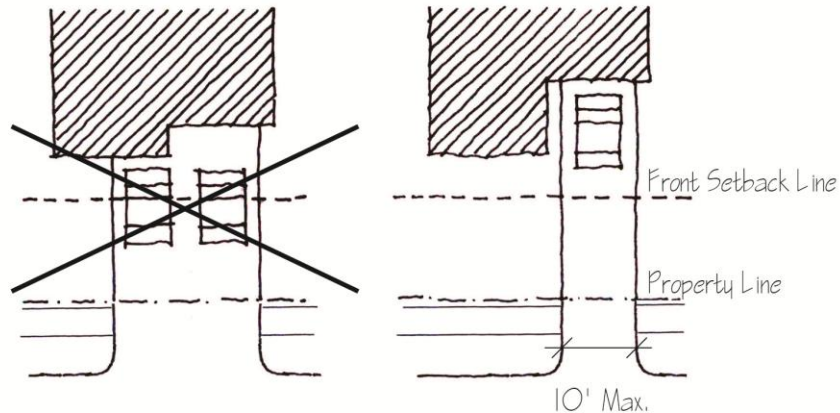

Plan (Not to Scale)

Figure WHWNOD-7
FRONT PARKING

- c. The enclosed or covered parking required under 19.28.090.D.2 and 19.36.311.D shall not be required in the WHWNOD.
- d. Driveways shall not be required to lead to a garage.
- e. Driveway width. Driveway pavement shall be limited to a maximum width of ten (10) feet when located within the front thirty percent (30%) of the property. Minimum driveway width shall be nine (9) feet.
- f. There shall be no more than three (3) feet between the side property line and the exterior edge of the driveway's pavement, unless additional spacing is necessary to accommodate the placement of porte cochères to the minimum extent necessary.

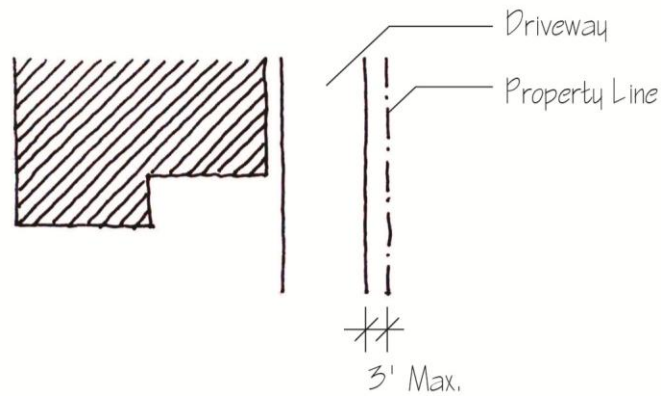

Plan (Not to Scale)

**Figure WHWNOD-8
DRIVEWAY PLACEMENT**

g. Visibility Considerations. Landscaping adjacent to a driveway shall not interfere with motorists' views of the sidewalk and pedestrians' views of vehicles exiting the driveway.

- (1) Nothing shall obstruct the motorist's view within the triangle drawn from five (5) feet back from the property line to a distance of ten (10) feet from the side of the driveway on the driver's right side as they make a forward exit from the property and ten (10) feet from the centerline of the driveway to the driver's left side.
- (2) Fences, walls, and vegetation that are over twenty-eight (28) inches in height shall not be located within this triangular zone, except that trees that do not have foliage below six (6) feet in height may be located in the triangular zone. Existing walls and landscape on adjacent property will be considered an existing non-conforming condition.

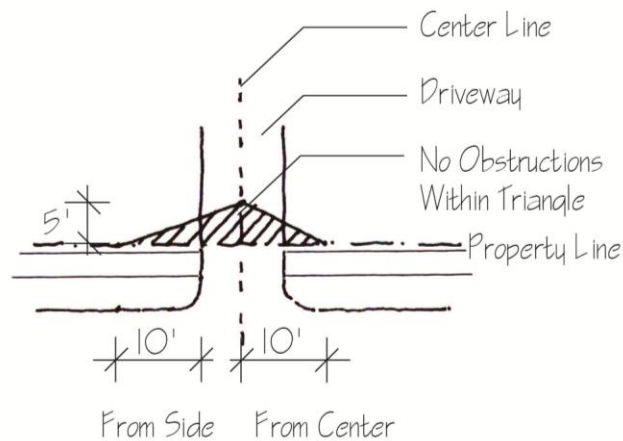

Plan (Not to Scale)

**Figure WHWNOD-9
DRIVEWAY VISIBILITY CONSIDERATIONS**

h. Garages and Carports.

- (1) *Attached garages.* A garage attached to the primary structure shall be set back a minimum of five (5) feet from the nearest front elevational plane (i.e. façade) of the building. Attached garages shall be included in the FAR calculation of the subject property.
- (2) *Detached garages.* A detached rear garage shall comply with 19.14.110.E.4, except that the area of detached rear garages, up to 400 square feet, shall not be included in a property's FAR calculation.
- (3) *Subterranean parking.* Subterranean or semi-subterranean parking shall not be permitted, unless (1) the subterranean parking utilizes lift mechanisms that are concealed and comply with all applicable noise regulations in Chapter 9.08 and Section 19.20.090 of the Municipal Code, and (2) there are no ramps visible from the street associated with subterranean parking. Code compliant subterranean parking shall not be included in FAR calculations.
- (4) *Carports.* Carports in the side or front yards shall be permanent structures. Pop-up or temporary shade structures shall not be used as carports in the side or front yards.

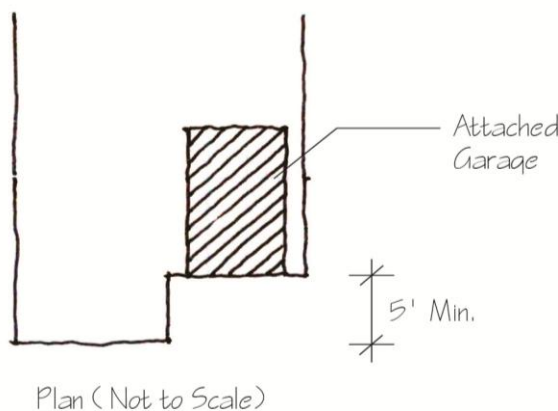
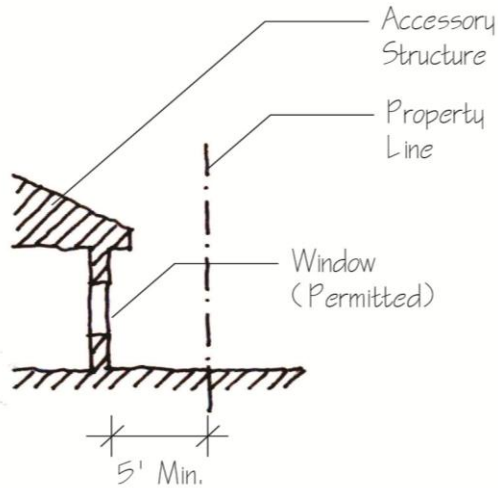

Figure WHWNOD-10
ATTACHED GARAGE

- (5) Refer to the West Hollywood West Design Guidelines for additional guidance on parking and driveway design.
3. Accessory Structures. This section modifies and supplements the standards set forth in Section 19.36.300 and Section 19.36.310 of the Municipal Code.
- a. Limitation on Use. Accessory structures shall not have cooking facilities, but living and sleeping quarters are permitted.
 - b. Location. Accessory structures may be placed up to the property line provided that they comply with all applicable building and fire safety codes.
 - c. Window and door placement. No window or door openings shall be located within five (5) feet of a property line.



Section (Not to Scale)

Figure WHWNOD-11
ACCESSORY STRUCTURE OPENINGS

- d. Size Limit. Accessory structures are not limited in size, but shall be included in the calculation of the FAR for the subject property and any applicable site coverage requirements. Detached rear garages, up to 400 square feet, are not included in the FAR calculation.

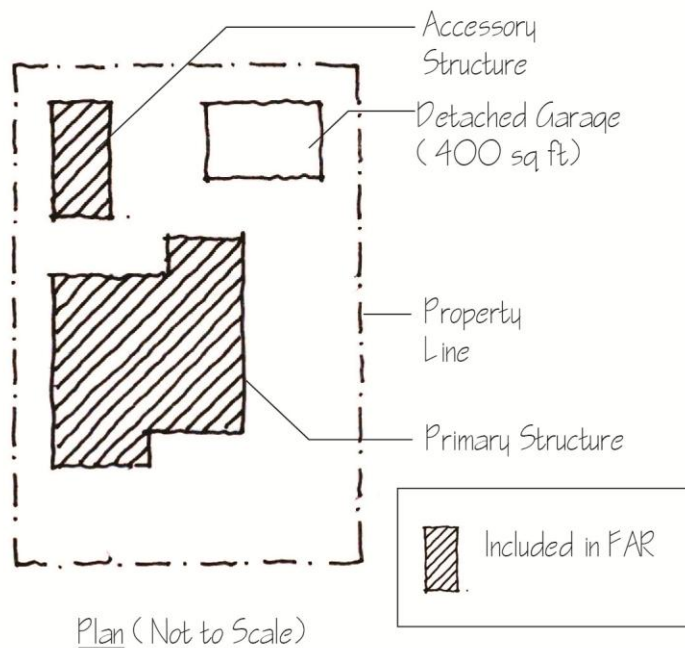

Plan (Not to Scale)

Figure WHWNOD-12
ACCESSORY STRUCTURE SIZE LIMIT

e. Distance Between Structures.

(1) *Distance Between Accessory Structures and Primary Structures.* A minimum distance of six (6) feet shall be required between any primary residential structure and an accessory structure established on the same parcel, and primary and accessory structures shall not be connected by a covered walkway.

(2) *Accessory Structures Attached to Detached Garages.* Accessory structures allowed within the rear yard may be attached to a detached garage, provided that the non-garage uses comply with the requirements of this Section. Accessory structures may not be built above the garage.

f. Site Coverage. The site coverage limitation under 19.36.300.A.3 shall not apply in the WHWNOD.

g. Height Limit. Accessory structures shall not exceed a height of twelve (12) feet and one story at the property line, and shall not exceed a height of fifteen (15) feet and one story when sited at least five (5) feet from the property line.

h. Exterior Lighting. Standards set forth in WHMC Section 19.20.100 shall apply. In addition, no exterior lighting shall be located within five (5) feet of a property line.

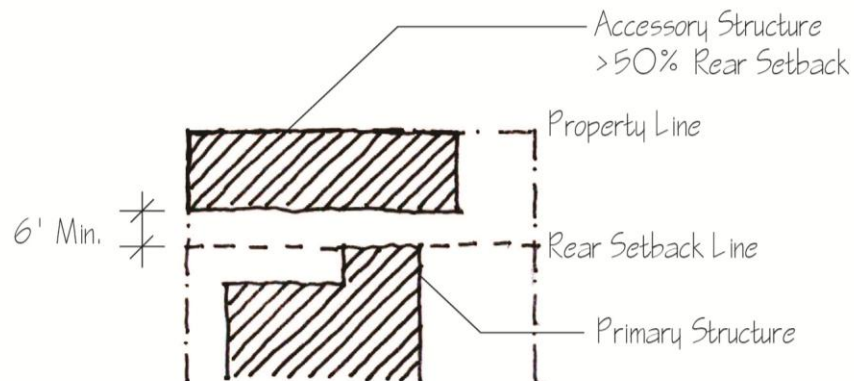

Plan (Not to Scale)

Figure WHWNOD-13
ACCESSORY STRUCTURE SITE COVERAGE

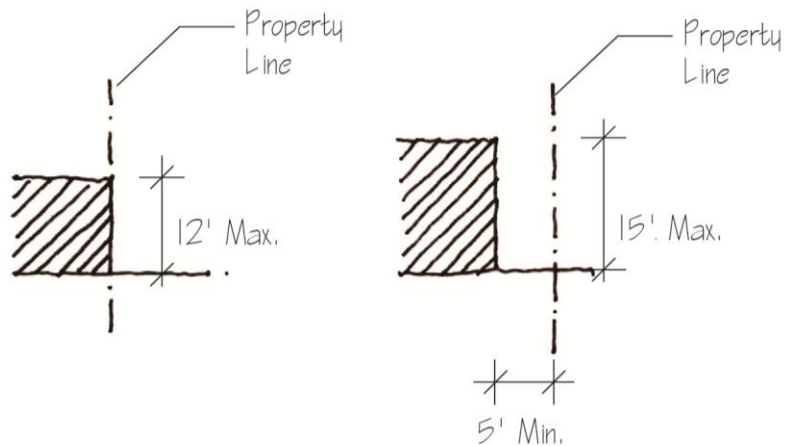

Section (Not to Scale)

**Figure WHWNOD-14
ACCESSORY STRUCTURE HEIGHT**

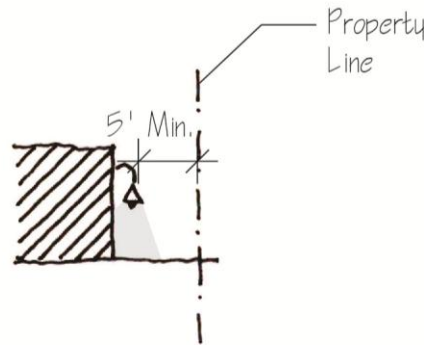

Section (Not to Scale)

**Figure WHWNOD-15
ACCESSORY STRUCTURE EXTERIOR LIGHTING**

- i. Design Standards. The structure shall be:
 - (1) Sited and constructed on the subject parcel in a manner that minimizes negative impacts (e.g. light, noise, etc.) to adjacent residents to the maximum extent feasible.
 - (2) Designed so that all roof drainage is directed to the subject site. All drainage shall be retained on-site, or directed to the street.
- j. Refer to the West Hollywood West Design Guidelines for additional guidance on accessory structure design.

4. Site and Landscape Standards. WHMC Sections 19.20.050, 19.26.050, 19.26.060, 19.26.070, and 19.26.080 apply in the WHWNOD except as modified or supplemented below.
 - a. Site Grading
 - (1) Retaining walls shall not exceed a height of forty-two (42) inches.
 - b. As part of a Development Permit, existing elevations of the project site shall not be raised or lowered more than eighteen (18) inches.
 - c. Fences and Walls
 - (1) Fences and walls erected along interior property lines shall be pre-finished on the outward face.
 - (2) *Visibility Considerations.* Nothing shall obstruct the motorist's view within the triangle drawn from five (5) feet back from the property line to a distance of ten (10) feet from the side of the driveway on the driver's right side as they make a forward exit from the property and ten (10) feet from the centerline of the driveway to the driver's left side.
 - (3) Fences or walls within the front setback shall be a minimum of eighteen (18) inches from the nearest edge of the sidewalk. The space between the sidewalk and fence or wall shall be covered with a groundcover or paving material. If vegetation is located within the space between the sidewalk and the fence or wall, its mature height shall not exceed eighteen (18) inches and adequate irrigation shall be provided.
 - (4) Entry elements or features shall be subject to the same height requirements as fences.
 - (5) Pedestrian gates may be solid for the allowed fence height for a maximum of four (4) feet wide.
 - d. Vegetation.
 - (1) Vegetation within the front setback and parkway that has a mature height over eighteen (18) inches shall be planted to maintain a clear area between its mature width and the nearest edge of the sidewalk. The space between the sidewalk and vegetation must be covered with a groundcover or paving material
 - (2) *Effect on Traffic or Public Safety.* Trees and shrubs shall be planted and maintained so that their mature height and width do not interfere with traffic safety sight areas, or public safety. Landscaping adjacent to a driveway and the walls of the building shall be designed not to interfere with motorists' views of the sidewalk and pedestrians' views of vehicles exiting the project. Nothing shall obstruct the motorist's view within the triangle drawn from five (5) feet back from the property line to a distance of ten (10) feet from the side of the driveway on the driver's right side as they make a forward exit from the property and ten (10) feet from the centerline of the driveway to the driver's left side.
 - e. Acoustical trespass. Refer to Chapter 9.08 and Section 19.20.090 of the Municipal Code.
 - f. Light trespass. Refer to Section 19.20.100 of the Municipal Code.

- g. Refer to the West Hollywood West Design Guidelines for additional guidance on site planning and landscape design.

F. . *Required Findings.*

1. When reviewing a Development Permit application in the WHWNOD, the review authority shall approve the Development Permit, with or without conditions, only if it first finds:
 - a. The findings in Section 19.48.050.A-C can be made in the affirmative;
 - b. Neighborhood Fit. The massing, scale, and proportion, as well as landscape, site, and streetscape design of the proposed project complement the existing neighborhood;
 - c. Quality Materials and Details. The proposed project exhibits use of quality materials and details appropriate to the design concept that will ensure proper execution of the design; and
 - d. Variety in New Construction. For new construction, that the building is a unique design and not identical to others on surrounding parcels.

The West Hollywood West Design Guidelines provide detailed guidance for finding neighborhood fit, quality materials and details, and variety in new construction

SECTION 7. The alphabetical list of definitions in Section 19.90.020 of Chapter 19.90 of Title 19 of the West Hollywood Municipal Code shall be amended to add the following new definitions:

Balcony. A platform on the outside of a building's upper floor, enclosed by a low wall, railing, or privacy screen, but otherwise open to the air. The frontage of the balcony is determined by its longest edge. A square balcony is subject to the more restrictive requirements. Balconies may have permanent overhead coverings, or may be open overhead. Balconies shall not have full-height walls for at least one side.

Basement, Full. Any building area with the majority of its volume below grade. A basement may be up to thirty (30) inches above finish grade.

Carport. An unenclosed shelter for a vehicle that consists of a roof supported by posts, and is built immediately adjacent to or is attached to a structure. A carport must have two (2) unenclosed sides.

Cooking facilities. An interior arrangement that provides, but is not limited to, the following features for the cooking of food: oven, stove, counter top burners, hot plate, electrical frying pan, toaster oven, or microwave.

Detached rear garage. An accessory structure that is utilized as a garage located behind the primary structure.

Driveway. A paved or improved surface intended for vehicular use, which leads from a public street onto a private property.

Invasive plant species. Plant species that are not native to California and have the growth rate and habits that lead to uncontrolled population growth and spread.

Living space. The enclosed and finished area of a structure that is intended for human use.

Mature height/width (vegetation). The dimension of the plant once it is complete in natural development. These dimensions are typically provided by nurseries. Long-living and healthy vegetation may continue to grow beyond the provided mature dimensions; these trees and plants may need to be pruned to prevent them from overgrowing the space they have been allowed.

Porte cochère. A roofed structure extending from a side entrance of a building over an adjacent driveway, and allowing vehicles to pass through.

Privacy Screen. Durable, permanent material that limits visibility. A privacy screen may not be transparent, but may be composed of translucent material. A privacy screen may be a louvered or perforated material.

Roof Deck. A balcony that is located on the uppermost level of a structure. For example, a balcony located on top of the first level of a one-story structure is a roof deck, and a balcony located on top of the second level of a two-story structure is a roof deck.

Roofline. Eaves, top of parapet, or edge where the roof meets the top of the building wall.

Semi-subterranean parking. Garage that has a finished floor elevation below grade, but does not have its total volume below grade.

Subterranean parking. Garage that has its total volume below.

Section 8. The new development standards in this ordinance do not apply to the currently pending development applications at the following addresses: 8924 Ashcroft, 9030 Ashcroft, 8901 Dorrington, 9015 Dorrington, 532 Huntley, 366 Huntley, 374 Huntley, 8724 Rangely, 547 West Knoll, 546 Westbourne. These applications were submitted to the City prior to adoption of Interim Urgency Ordinance 14-913U, imposing a moratorium on new construction, second story additions and additions over 500 square feet, and Interim Ordinance No. 14-935U, extending the moratorium until December 31, 2014 to allow staff to continue work with the community to develop a Neighborhood Overlay District and Design Guidelines for the West Hollywood West Neighborhood, and are not subject to the moratorium or the new standards.

PASSED, APPROVED AND ADOPTED by the City Council of the City of West Hollywood at a regular meeting held the 3rd Day of November, 2014, by the following vote:

AYES: Councilmember:
NOES: Councilmember:
ABSENT: Councilmember:
ABSTAIN: Councilmember:

JOHN D'AMICO, MAYOR

ATTEST:

YVONNE QUARKER, CITY CLERK

STATE OF CALIFORNIA)
COUNTY OF LOS ANGELES)
CITY OF WEST HOLLYWOOD)

I, YVONNE QUARKER, City Clerk of the City of West Hollywood, do hereby certify that the foregoing Ordinance No. 14-___ was duly passed, approved and adopted by the City Council of the City of West Hollywood at a regular meeting held on the ___ day of _____, 2014, after having its first reading at the regular meeting of said City Council on the ___ day of _____, 2014.

I further certify that this ordinance was posted in three public places as provided for in Resolution No. 5, adopted the 29th day of November, 1984.

WITNESS MY HAND AND OFFICIAL SEAL THIS ___ DAY OF _____, 2014.

YVONNE QUARKER, CITY CLERK